

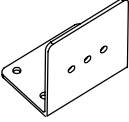

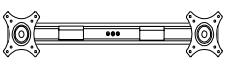



A  Mounting Bracket 1 Pc	B  Monitor Rail Assembly 1 Pc	C  M6 x 13 3 Pcs	D  M6 Nut 3 Pcs	E  4mm Allen Key 1 Pc	F  10mm spanner 1 Pc	G  13mm spanner 1 Pc	H  Screen Screw 2 Bags
--	--	---	--	--	---	---	---

STEP 1



Rotate bracket like this to increase the height of monitors

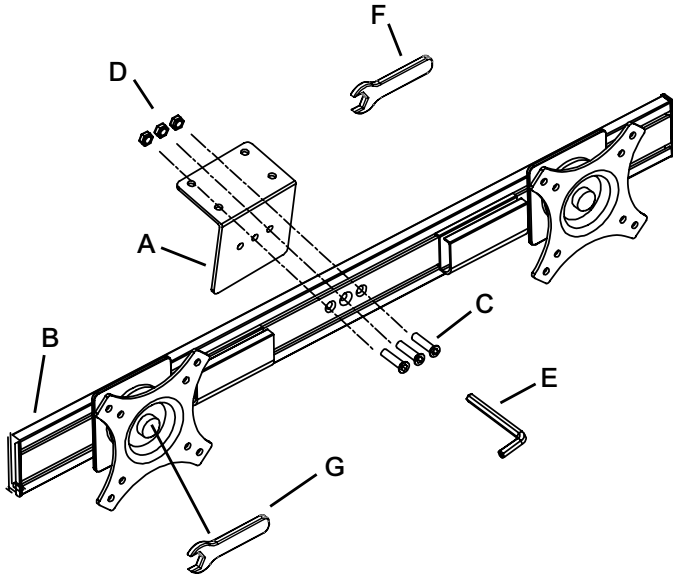
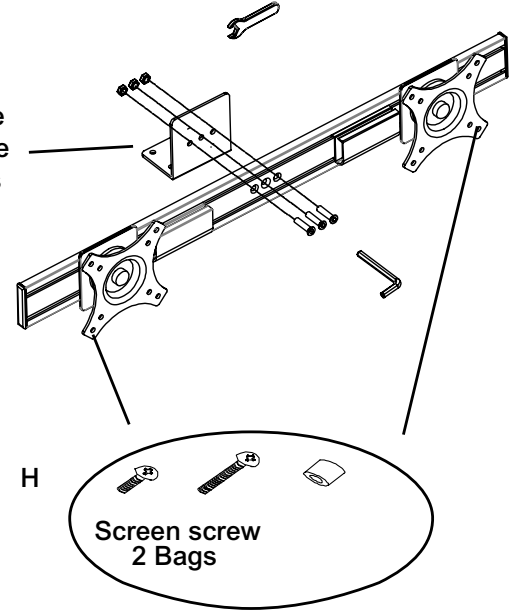

Customer can assemble computer screen to bracket with "H" bag screws.

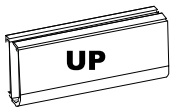
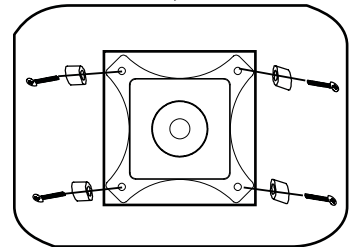

NOTE:

Make sure the opening of "Up" is facing upwards.

Set part "A" (Mounting bracket) use drawing on the left to assemble the arm at a lower height.

Set part "A" (Mounting bracket) use drawing on the right to assemble the arm at a higher height.

IMPORTANT NOTE:

- Place all laminated parts on a clean and smooth surface such as a rug or carpet to avoid the parts from being scratched.
- Check to be sure that you have all parts and hardware.
- Remove all wrapping materials, including staples and packing straps before you start to assemble.
- Don't tighten all screws/bolts until all completely assembled.
- Keep all hardware parts out of reach of children.
- It is recommended for 2 persons to complete this assembly.

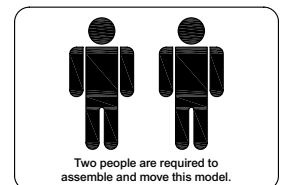

STEP 2

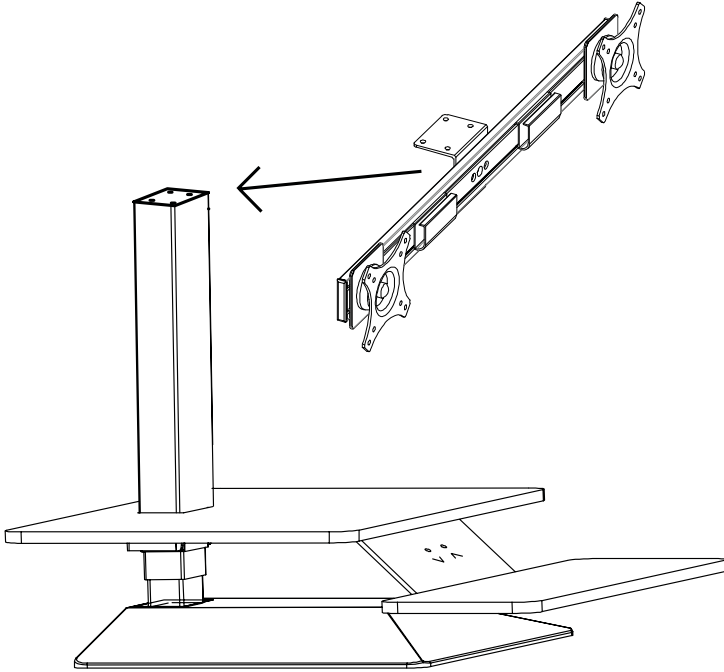

Tool: 4mm Allen key Wrench
Parts: M6X10 4 pcs

STEP 3

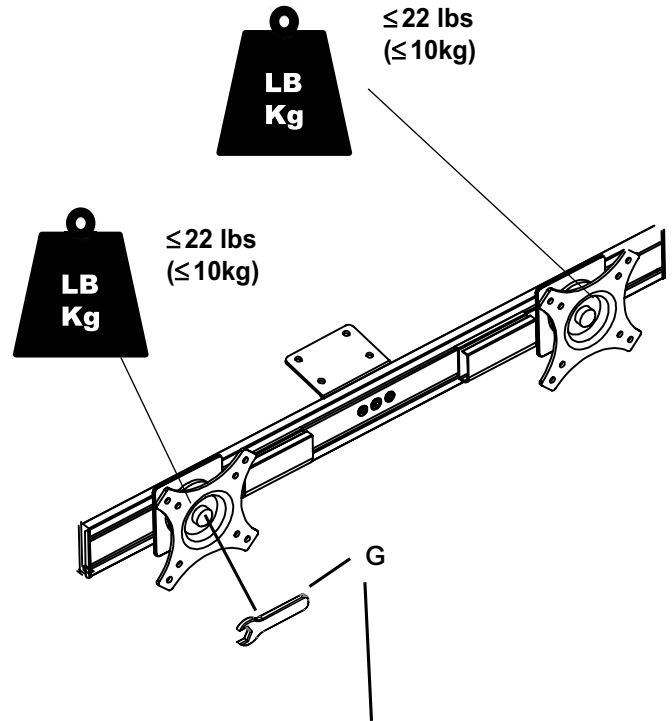

Attention:

Tool "G" (13 mm spanner) is used for tightening Part B to computer screen. If computer screen is loose, remove plastic cover and tighten it.







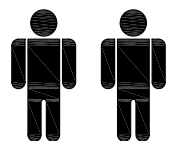

CAUTION: DO NOT EXCEED MAXIMUM LISTED WEIGHT CAPACITY. SERIOUS INJURY OR PROPERTY DAMAGE MAY OCCUR!

IMPORTANT NOTE:

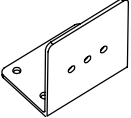
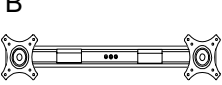
- Place all laminated parts on a clean and smooth surface such as a rug or carpet to avoid the parts from being scratched.
- Check to be sure that you have all parts and hardware.
- Remove all wrapping materials, including staples and packing straps before you start to assemble.
- Don't tighten all screws/bolts until all completely assembled.
- Keep all hardware parts out of reach of children.
- It is recommended for 2 persons to complete this assembly.



Two people are required to assemble and move this model.

A  Support de fixation 1 Pc	B  Barre de support pour le moniteur 1 Pc	C  M6 x 13 3 Pcs	D  Écrou M6 3 Pcs	E  Clé hexagonale de 4 mm 1 Pc	F  Clé de 10 mm 1 Pc	G  Clé de 13 mm 1 Pc	H  Vis pour moniteur 2 sacs
---	--	---	--	---	---	---	--

ÉTAPE 1

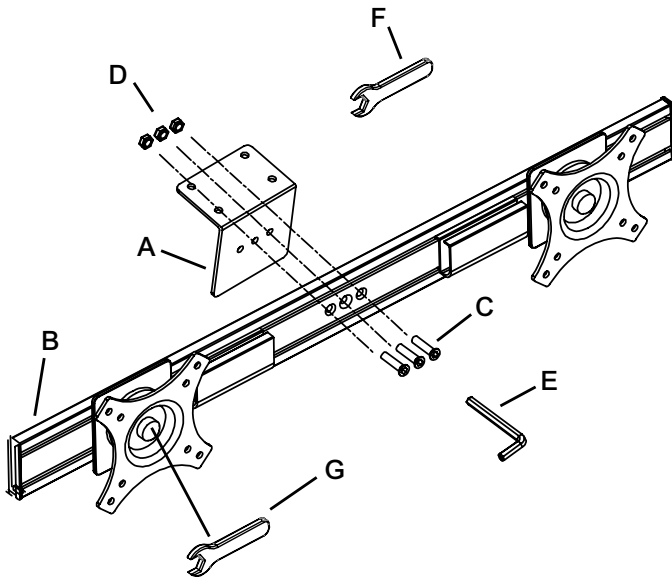

Orientation du support de fixation pour un moniteur en position haute

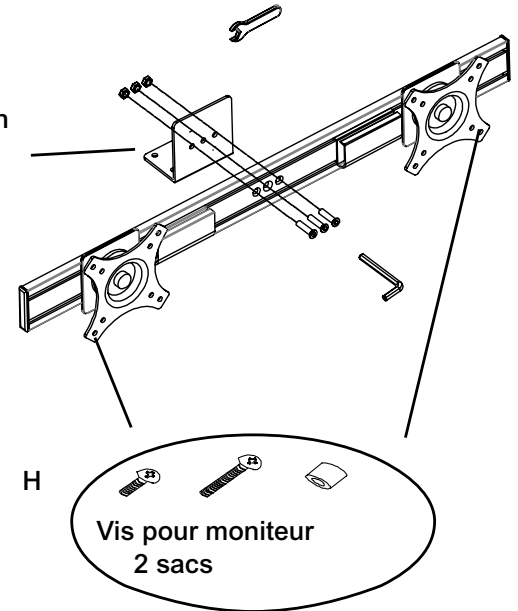

Utilisez les pièces du sac H pour fixer un moniteur au support

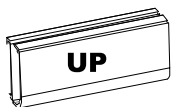
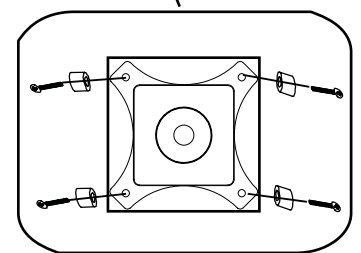

REMARQUE :

Assurez-vous que la marque «UP » est orientée vers le sommet.

Moniteur en position basse : Orientez le support de fixation A tel qu'illustré dans le diagramme de gauche.

Moniteur en position haute : Orientez le support de fixation A tel qu'illustré dans le diagramme de droite.

NOTE IMPORTANTE :

- Déposez toutes les pièces laminées sur une surface propre et douce comme sur une carpe ou un tapis afin d'éviter l'éraflure des pièces.
- Vérifiez pour vous assurer que vous avez toutes les pièces et toute la quincaillerie.
- Enlevez tout le matériel d'emballage, incluant les agrafes et les courroies d'emballage avant de débiter l'assemblage.
- Ne serrez pas aucun des boulons/vis avant d'avoir assemblé toutes les pièces.
- Gardez toutes les pièces de quincaillerie hors de portée des enfants.
- Il est recommandé que 2 personnes effectuent cet assemblage.



2 personnes sont requises pour l'assemblage et le déplacement de ce modèle.

ÉTAPE 2

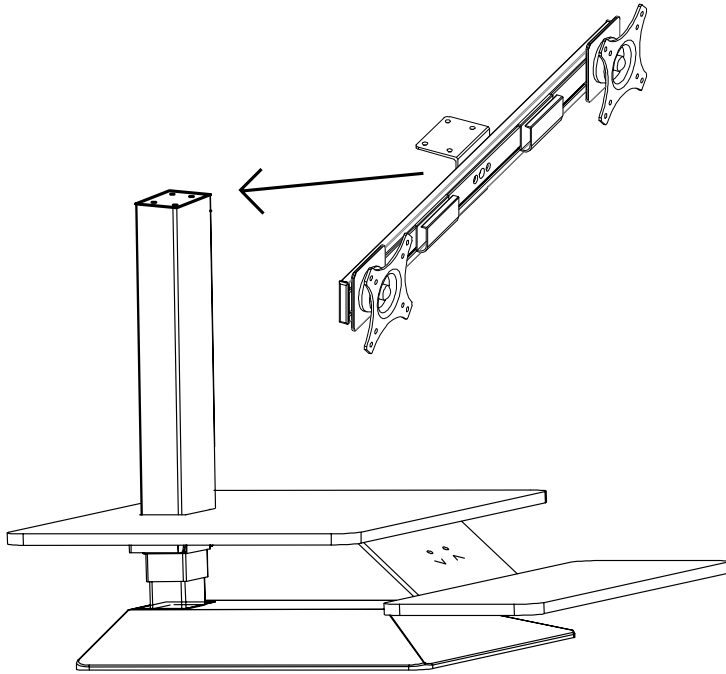

Outil (poste de travail) : clé hexagonale de 4 mm
Pièces (poste de travail) : 4 vis M6*10

ÉTAPE 3

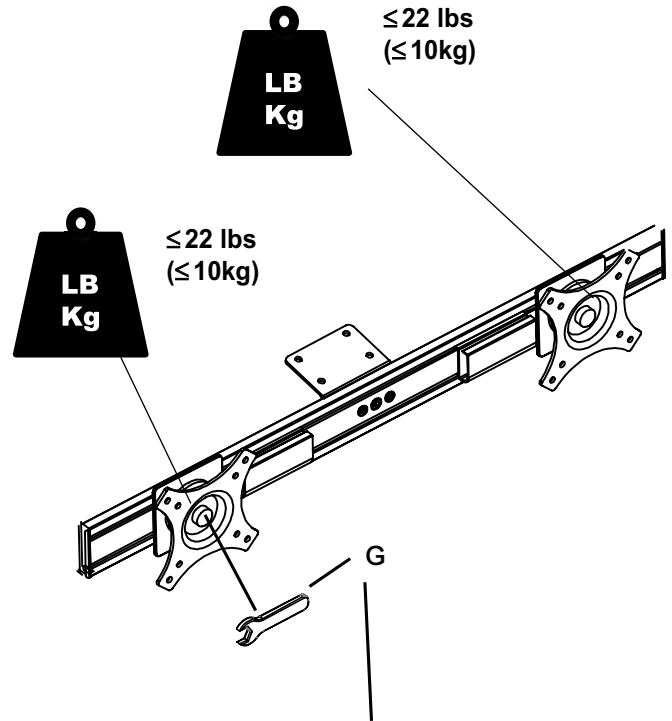

Remarque :

Si le moniteur n'est pas bien fixé au bras de support B, retirez le couvercle et resserrez l'écrou avec l'outil G (clé de 13 mm).







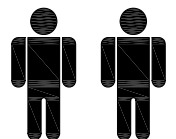

AVERTISSEMENT: VEUILLEZ RESPECTER LA CHARGE MAXIMALE INDICUÉE AFIN D'ÉVITER LES RISQUES DE BLESSURE OU DE DOMMAGE MATÉRIEL!

NOTE IMPORTANTE :

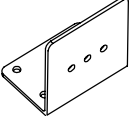
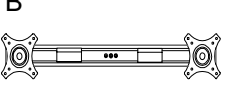
- Déposez toutes les pièces laminées sur une surface propre et douce comme sur une carpeite ou un tapis afin d'éviter l'éraflure des pièces.
- Vérifiez pour vous assurer que vous avez toutes les pièces et toute la quincaillerie.
- Enlevez tout le matériel d'emballage, incluant les agrafes et les courroies d'emballage avant de débiter l'assemblage.
- Ne serrez pas aucun des boulons/vis avant d'avoir assemblé toutes les pièces.
- Gardez toutes les pièces de quincaillerie hors de portée des enfants.
- Il est recommandé que 2 personnes effectuent cet assemblage.



2 personnes sont requises pour l'assemblage et le déplacement de ce modèle.

<p>A</p>  <p>Soporte de montaje 1 Pc</p>	<p>B</p>  <p>Unidad del riel del monitor 1 Pc</p>	<p>C</p>  <p>M6 x 13 3 Pcs</p>	<p>D</p>  <p>Tuerca M6 3 Pcs</p>	<p>E</p>  <p>Llave Allen de 4 mm 1 Pc</p>	<p>F</p>  <p>Llave inglesa de parada de 10 mm 1 Pc</p>	<p>G</p>  <p>Llave inglesa de parada de 13 mm 1 Pc</p>	<p>H</p>  <p>tornillo de la pantalla 2 bolsas</p>
---	---	--	--	---	--	--	---

PASO 1

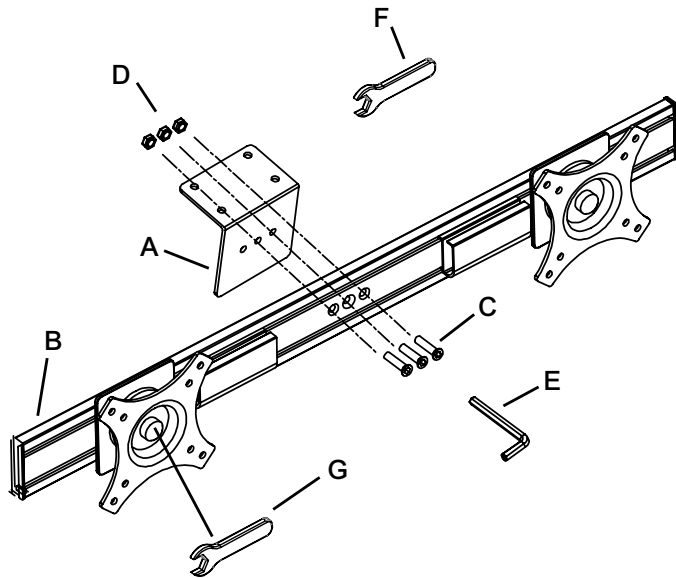

Gire los soportes de esta forma para aumentar la altura de los monitores

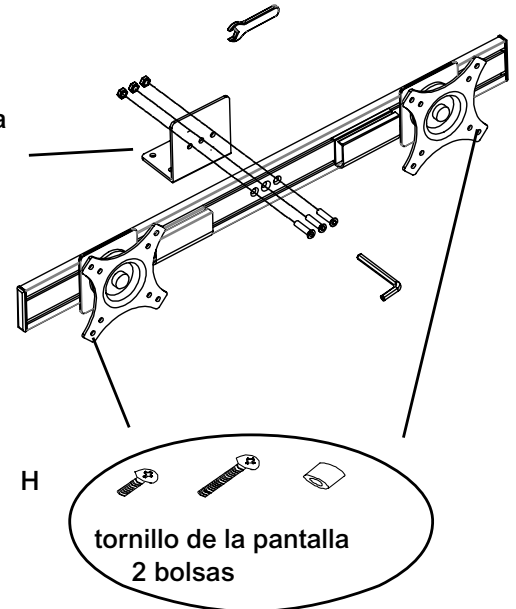

El cliente puede fijar la pantalla de la computadora en el soporte con los tornillos/bolsa "H".

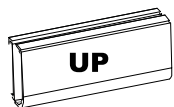
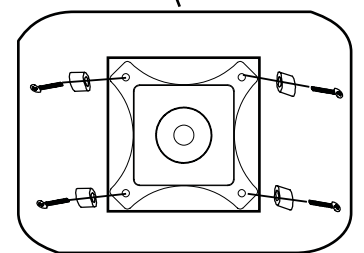

NOTA:

Asegúrese de que la abertura de "UP" esté orientada hacia arriba.

Moniteur en position basse : Orientez le support de fixation A tel qu'illustré dans le diagramme de gauche.

Moniteur en position haute : Orientez le support de fixation A tel qu'illustré dans le diagramme de droite.

NOTA IMPORTANTE:

- Coloque todas las partes laminadas sobre una superficie limpia y uniforme (como un tapete o la alfombra) para evitar que se rayen.
- Asegúrese de tener todas las partes y la ferretería.
- Antes de empezar a ensamblar remueva todos los materiales de empaque, incluyendo grapas y cintas.
- No apriete todos los tornillos o pernos hasta haber ensamblado todas las piezas.
- Mantenga toda la ferretería fuera del alcance de los niños.
- Se recomienda que dos personas realicen este ensamble.

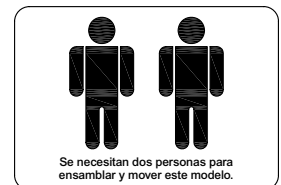

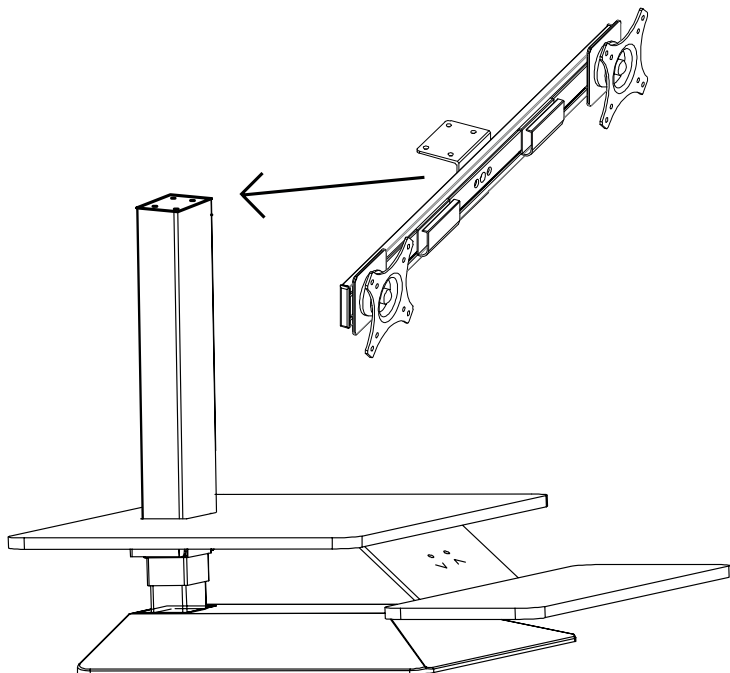
PASO 2

Herramienta: Llave Allen de 4 mm
Piezas: 4 tornillos M6X10

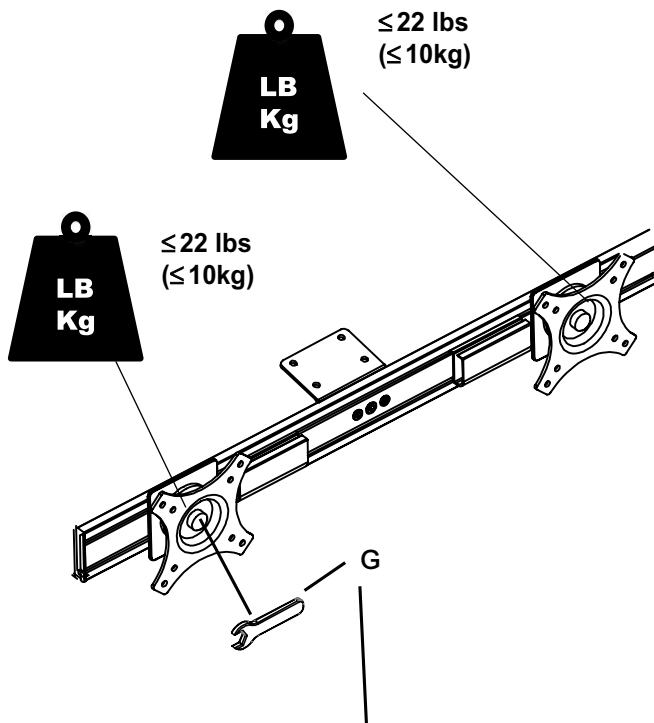
PASO 3

Atención:

La herramienta "G" (llave inglesa de parada de 13 mm) se utiliza para apretar la Parte B en el monitor. Si la pantalla de la computadora está floja, quite la cubierta de plástico y apriétela.



PRECAUCIÓN: NO SOBREPASE LA CAPACIDAD MÁXIMA DE PESO LISTADA. ¡NO SEGUIR ESTA PRECAUCIÓN PODRÍA OCASIONAR LESIÓN GRAVE O DAÑO A LA PROPIEDAD!

NOTA IMPORTANTE:

- Coloque todas las partes laminadas sobre una superficie limpia y uniforme (como un tapete o la alfombra) para evitar que se rayen.
- Asegúrese de tener todas las partes y la ferretería.
- Antes de empezar a ensamblar remueva todos los materiales de empaque, incluyendo grapas y cintas.
- No apriete todos los tornillos o pernos hasta haber ensamblado todas las piezas.
- Mantenga toda la ferretería fuera del alcance de los niños.
- Se recomienda que dos personas realicen este ensamble.

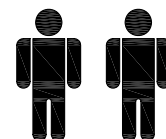

Se necesitan dos personas para ensamblar y mover este modelo.

Instructions

CALL US FIRST! DO NOT RETURN TO STORE.

For immediate help with assembly or product information call our toll-free number: **1-888-598-7316** Mon. - Fri. 7am to 7 pm CST
Our staff is ready to provide assistance. Damaged or missing parts ship from our facility in 1-2 business days.

Please provide the following information:

1. Full Name
2. Physical Address – do not include P.O. Box as our carriers cannot deliver to P.O. Boxes
3. Phone Number
4. Model Number
5. Part Number
6. Invoice #
7. Date of Purchase

Note: Our policy is to send all parts requests via normal ground transportation. If your requirements are to have these parts via overnight/next day, please provide your designated carrier and account number. Replacement panels are not available. If any damage has occurred during shipment please return the entire unit to place of purchase for credit and replacement. Original invoice may be required.

Before you begin:

Open, identify and count all parts prior to assembly. Lay out the parts on a non-abrasive surface such as carpet or blanket.

Instructions

APPELEZ-NOUS D'ABORD! NE REVENEZ PAS AU MAGASIN.

Pour obtenir une aide immédiate concernant l'assemblage ou des informations sur les produits, appelez notre numéro sans frais :
1-888-598-7316 Lun. - vend. 7h à 19 h CST Notre personnel vous attend pour vous offrir son aide.
Les pièces endommagées ou manquantes sont expédiées de nos locaux sous 1 à 2 jours ouvrables.

Veillez inclure les informations suivantes :

1. Nom complet
2. Adresse physique – ne pas inclure de boîte postale, car nos porteurs ne peuvent pas livrer à ces boîtes.
3. Numéro de téléphone
4. Numéro de modèle
5. Numéro de pièce
6. Numéro de facture
7. Date d'achat

Remarque : Notre politique est d'envoyer toutes les pièces demandées par transport terrestre normal. Si vous voulez recevoir ces pièces le jour suivant, indiquez votre porteur désigné ainsi qu'un numéro de compte. Nous ne fournissons pas de panneaux de rechange. En cas d'endommagement en cours de transport, renvoyez l'unité entière au lieu d'achat pour recevoir un crédit ou un échange. La facture originale vous sera peut-être demandée.

Avant de commencer:

Ouvrez, identifiez et comptez toutes les pièces avant l'assemblage. Disposez à plat les pièces sur une surface non abrasive comme un tapis ou une couverture.

Instrucciones

¡LLÁMENOS PRIMERO! NO DEVUELVA EL PRODUCTO A LA TIENDA.

Para recibir ayuda inmediata con el ensamble o información del producto, llame a nuestro número gratuito: **1-888-598-7316**
De lunes a viernes de 7 a.m. a 7 p.m., hora del Centro. Nuestro personal está preparado para brindarle asistencia.
Las partes dañadas o faltantes saldrán de nuestras instalaciones en el transcurso de 1 a 2 días hábiles.

Recuerde proporcionar la siguiente información:

1. Nombre completo
2. Domicilio físico – No incluya apartados postales debido a que no podemos realizar entregas en un apartado postal.
3. Número telefónico
4. Número de modelo
5. Número de parte
6. Número de factura
7. Fecha de compra

Nota: Nuestra política es enviar todas las solicitudes de partes por transporte terrestre regular. Si usted solicitó el envío de estas partes durante la noche o con entrega al día siguiente, proporcione el nombre de su compañía de mensajería y su número de cuenta. Los paneles de repuesto no están disponibles. Si ocurrió algún daño durante el envío, devuelva la unidad completa al lugar de compra para su devolución o reposición. Es posible que le pidan la factura original.

Antes de iniciar:

Abra, identifique y cuente todas las partes antes del ensamble. Coloque todas las partes en una superficie no abrasiva, como una alfombra o sábana.